

N A P - 100AD
(CATALYTIC TYPE GAS SENSOR)
Handling manual

Nemoto Sensor Engineering Co., Ltd.
4-10-9, Takaido-higashi, Suginami-ku, Tokyo
TEL. 03-3333-2760
FAX. 03-3333-7344
E-mail : sensor2@nemoto.co.jp
URL : <http://www.nemoto.co.jp>

NAP-100AD is a catalytic type gas sensor employed for mainly commercial or semi-industrial applications. Since this sensor has a simple explosion proof structure, it is applicable for commercial fields as it is, however intrinsic explosion proof enclosure is also recommended for industrial application.

1. Features and application of NAP-100AD

1) Features

- Good stability
- Excellent repeatability and detection accuracy
- Good linearity against gas concentration
- Quick response
- High temperature resistive

2) Applications

- Gas alarm or detector for general combustible gases
- Gas densitometer
- Driving module for gas leakage detector

2. Maximum ratings

- Supply voltage to sensor
AC 3.3V (50 – 60Hz)
DC 3.3V
- Ambient temperature and humidity in operation
Temperature –40 ~ +260°C
Humidity less than 99%RH (less than 100 degree C)
(without dew condensation)
- Ambient temperature and humidity in storage
Temperature –40 ~ +80°C
Humidity less than 99%RH
(without dew condensation)

3. Ratings

- Supply voltage to sensor
AC $2.6 \pm 0.13V(50-60Hz)$
DC $2.6 \pm 0.13V$
- Current(when 2.5V is supplied)
AC 160 ~ 180mA(50–60Hz)
DC 160 ~ 180mA
- Ambient temperature and humidity in operation
Temperature –20 ~ +200°C (less than 100 degree C)
Humidity less than 95%RH
(without dew condensation)
- Ambient temperature and humidity in storage
Temperature –30 ~ +70°C
Humidity less than 99%RH
(without dew condensation)

4. Detection range

It can measure/detect whole combustible gases less than 100%LEL, but excellent accuracy of linearity within +/-10% can be obtained when the gas concentration is to be less than 50%LEL. If wider measurement range is necessary, NAP-100AC is recommended.

5. Response and recovery time

From clean air to 10%LEL

T90 : less than 10sec.

From gas to clean air

T90 : less than 20sec.

(This time is dependent on ambient conditions.)

6. Specifications

• Detected gases	General combustible gases
• Measuring range	1 - 100%LEL
• Gas sensitivity	More than 75mV/% of methane
• Repeatability in the same day	Less than 2%
• Methane sensitivity stability	Less than 1%/month
• Zero offset stability	Less than 1mV/month
• Resolution	100ppm of methane
• Zero offset value	-35 - +35mV in clean air

7. Relative sensitivity

	Gases	Chemical formula	LEL (%)	Relative sensitivity
1	Methane	CH ₄	5.0	100
2	Propane	C ₃ H ₈	2.2	75
3	Iso-Butane	C ₄ H ₁₀	1.8	75
4	n-Pentane	C ₅ H ₁₂	1.4	80
5	n-Hexane	C ₆ H ₁₄	1.2	75
6	n-Heptane	C ₇ H ₁₆	1.05	65
7	Iso-Octane	C ₈ H ₁₈	0.95	60
8	Methanol	CH ₃ OH	6.7	125
9	Ethanol	C ₂ H ₅ OH	3.3	95
10	Iso-Propanol	C ₃ H ₇ OH	2.2	80
11	Acetone	(CH ₃) ₂ CO	2.6	85
12	Toluene	C ₆ H ₅ CH ₃	1.2	65
13	Ethyl acetate	CH ₃ COOC ₂ H ₅	2.2	70
14	Hydrogen	H ₂	4.0	110
15	Ammonia	NH ₃	15.0	150
16	Cyclohexane	C ₆ H ₁₂	1.3	75
17	Ethylene	C ₂ H ₄	2.7	95

Note) This sensor is not applicable for the detection of acetylene.

The previous table can be used for quick reference as below.

Example)

In case 50%LEL ethanol is measured by detection equipment calibrated with 0 – 100%LEL of methane, the following conversion is made from the table.

$$(95 \times 50)/100=47.5\%LEL \text{ by methane scale}$$

8. Typical sensitivity characteristics

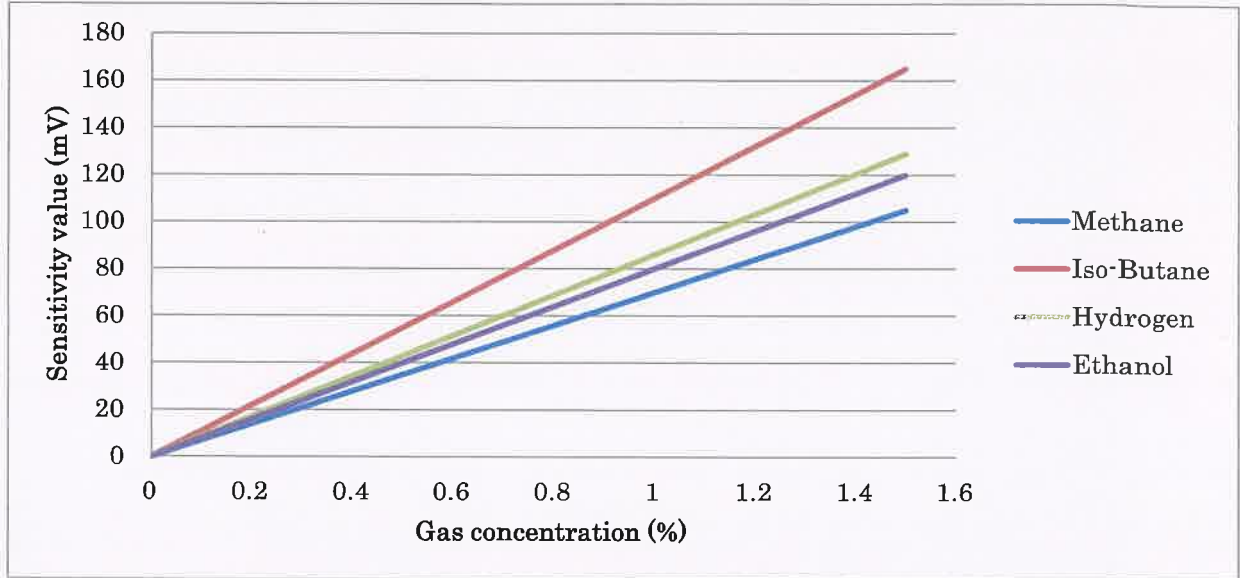

9. Structure and dimension

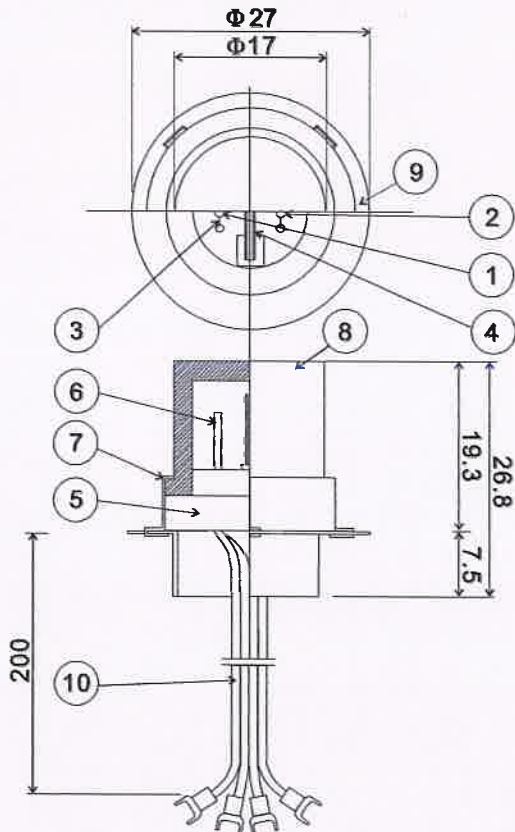

No.	Part name	Material	Remarks
1	Sensor		
2	Compensator		
3	Filament coil	Platinum	0.03 mm Diameter
4	Separator	SUS 304	t = 0.1
5	Mount base	Phenol resin	
6	Pins	Pure Ni	0.8 mm diameter
7	Strainer	SUS-304	t = 0.3
8	Sintered metal filter	SUS-316	
9	Fixer	SUS-304	t = 0.5
10	Lead wire	UL3266 FRPE	

10. Recommended circuit

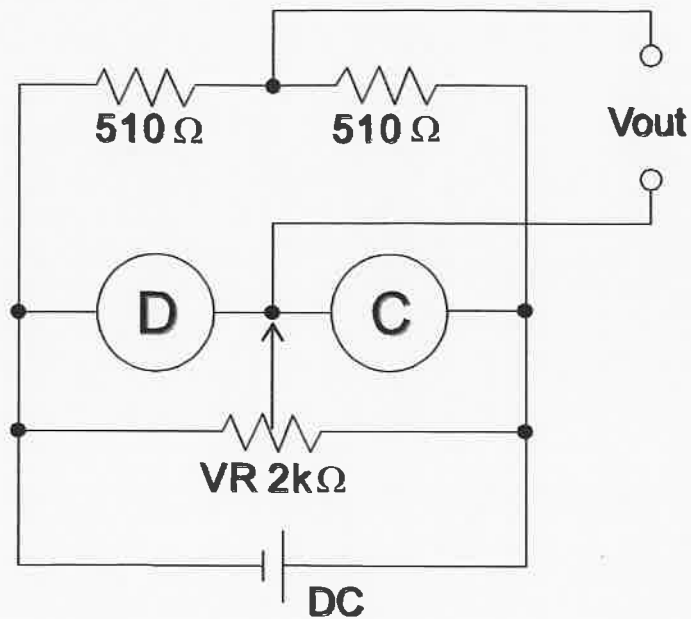

Note)

Fixed resistors in the above circuit have to be metal film resistor, and variable resistor has to be cermet or metal film type. If the carbon type is employed, zero offset value is not stable because the resistance values of them are varied.

11. Evaluation method of sensor

(1) Test equipment

Outline of test equipment is shown as below.

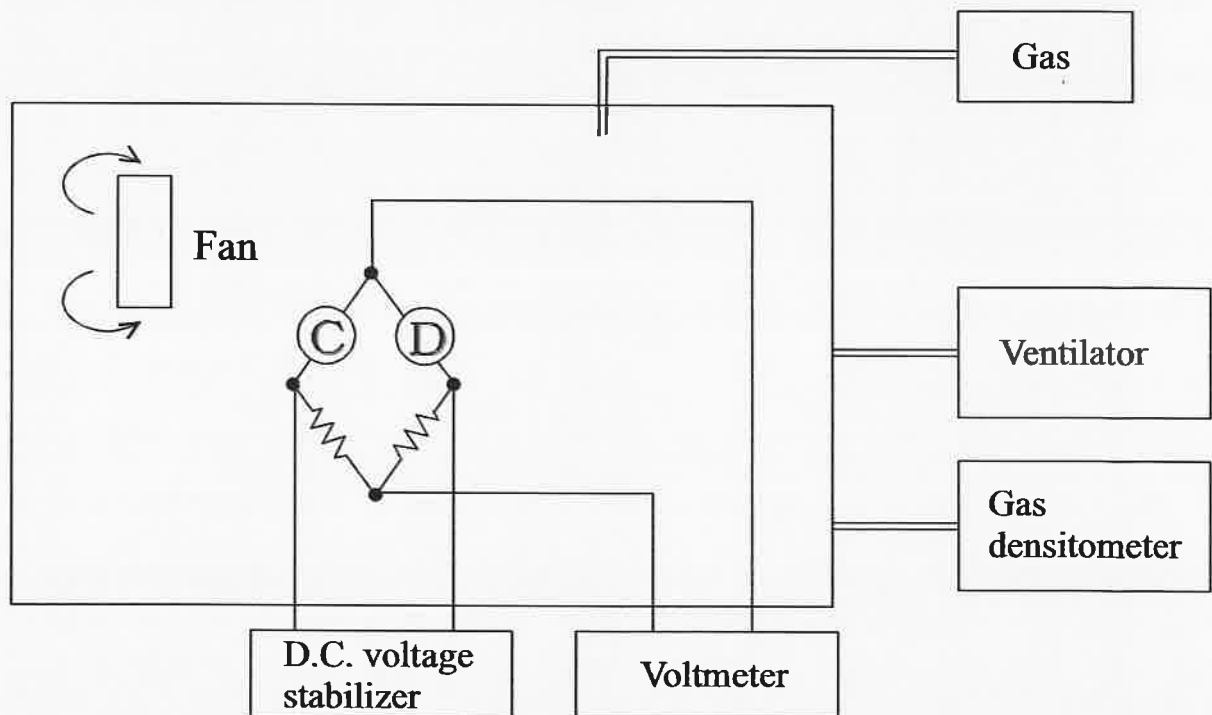

Remarks)

1) Test chamber

- Material of test chamber is to be like as metal or glass which does not exhale and adsorb gases.
- Volume of test chamber is to be 1 liter per 1pc. of sensor.

2) Circumstance

- Clean air is to be available. Dirty air in a factory which contains combustible gases or organic solvent vapor is not to be supplied to test chamber.

3) Gas densitometer

- IR gas densitometer is suitable.

4) Air agitation in test chamber

- Air agitation in test chamber is to be noticed in order not to flow air to sensor directly. Air velocity is to be less than 0.5m/sec.

5) Power supply

- Sensor is available by AC power and DC power, but DC power supply is to be recommended for more accurate measurement.

6) Digital volt meter

- Since the impedance of sensor is fairly low, general digital volt meter having over 100kohm as input impedance is recommended.

7) Ventilation

- Ventilator with ventilation ability of over 10 times per minute of the volume of test chamber is to be necessary for the next measurement.

8) Installation position of sensor in test chamber

- When the sensor is installed in test chamber, it should be noticed that every sensor is to be in constant position because output signal is changed in case that position of sensor is changed. If the rough evaluation is enough, such notice is not needed.

(2) Adjustment of gas concentration

Adjustment of gas concentration is to be conducted by volume method or by using IR gas densitometer. In case of volume method, gas volume of injection to chamber is obtained from the calculation formula described as below.

$$V(ml) = V_i \cdot C \cdot 10^{-6} \frac{273 + T_r}{273 + T_c}$$

V ; Gas volume to be injected

V_i ; Inner volume of test chamber (ml)

C ; Target gas concentration (*ppm*)

T_c ; Temperature in test chamber ($^{\circ}\text{C}$)

T_r ; Room temperature ($^{\circ}\text{C}$)

(3) Evaluation method

1) Preliminary aging

- Before evaluation of sensor, preliminary aging at rated voltage for over 1 hr. is to be necessary.

2) Measurement

- At first, output voltage in clean air is to be measured. It should be confirmed that output voltage has to be stable, not fluctuated.
- Output voltage is to be measured after the designated volume of gas is injected into a test chamber.
- After measurement, air in test chamber is to be exhaled compulsory.

(4) Notice on handling

- Sensor is to be gently handled without drop or shock.
- Handling is to be avoided in a location which corrosive gases and poisoned gases exist.
- Sensor is not to be dipped in water.