

Nitric Oxide Sensor 0-2000 ppm

Performance Characteristics

Part Number	CLE-0523-400
Nominal Range	0 to 2000 ppm
Maximum Overload	2000 ppm
Sensitivity	0.13 ± 0.06 µA/ppm
Baseline (20 °C)	-0.2 ~ 1.44 µA
Baseline Drift (-20 to 50 °C)	-2 to 20 ppm equivalent
Resolution	1 ppm
Response Time (T90)	≤ 60 seconds
Linearity	Linear
Long Term Output Drift	< 2% signal/month

Operation Conditions

Temperature Range	-20 °C to 50 °C
Operating Humidity	15 to 90%RH non-condensing
Pressure Range	90 to 110 kPa
Bias Potential	+300 mV
Storage Life	6 months in sealed container
Storage Temperature	0 °C to 20 °C
Expected Operating Life	2 years in air
Warranty	12 months from date of despatch

Physical Characteristics

Weight	5 g (approx)
Orientation Sensitivity	None

Outline Dimensions

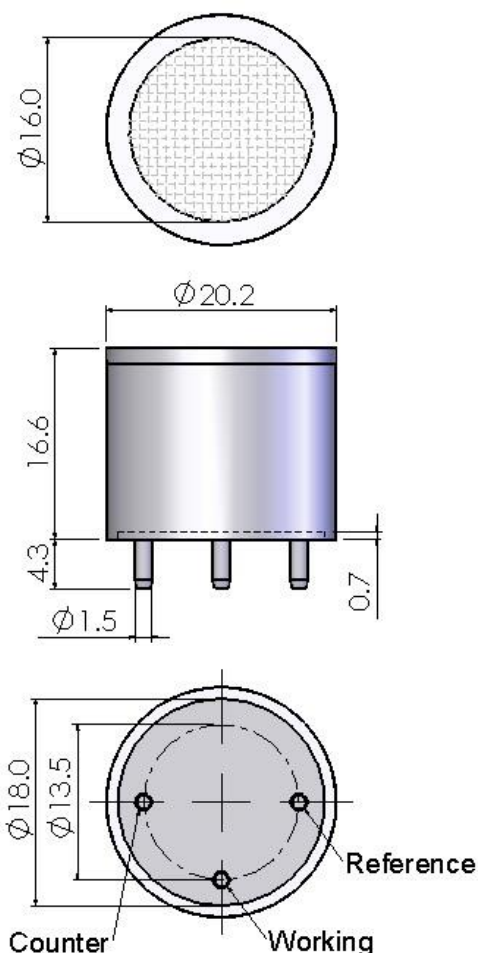

All dimensions are in millimeters.
All tolerances are ±0.2mm.

Note: PCB sockets are recommended for the sensor pin connection. Soldering to the sensor should be avoided

Temperature Dependence

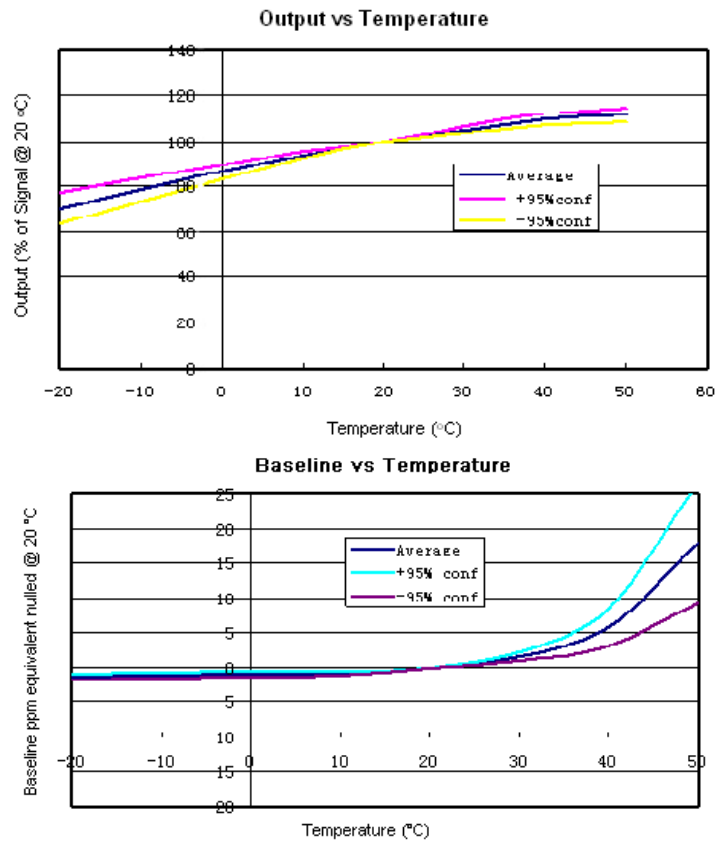

Cross-sensitivity Data

Gas	Concentration (ppm)	Output Signal (ppm NO equivalent)
Carbon Monoxide	300	0
Sulphur Dioxide	5	0
Nitrogen Dioxide	5	2
Hydrogen Sulphide	15	7

Notes:

1. All performance specifications are based upon the following environment conditions: 20 °C, 50% relative humidity and 1 atmospheric pressure (100 kPa or ambient pressure).
2. Recommend calibration with target gas. If calibration with a cross sensitivity gas, we cannot ensure the accuracy of calibration and measurement.
3. The cross sensitivity may fluctuate between +/- 30% and may differ from batch to batch or from sensor's life time.
4. The cross sensitivities are including but not limited to the above gases. It may also respond to other gases.